

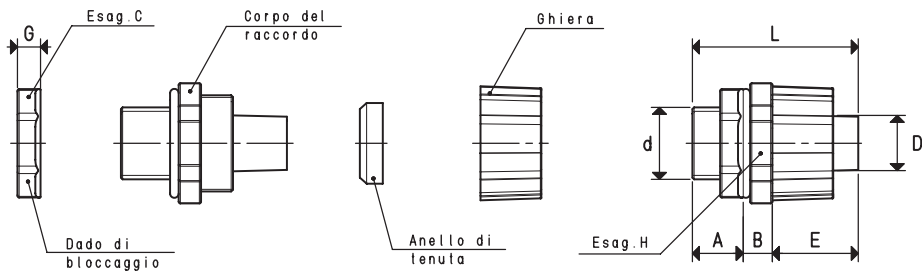

## RACCORDI PER TUBI FLESSIBILI TPR

Sono disponibili i disegni 3D sul sito [vuototecnica.net](http://vuototecnica.net)

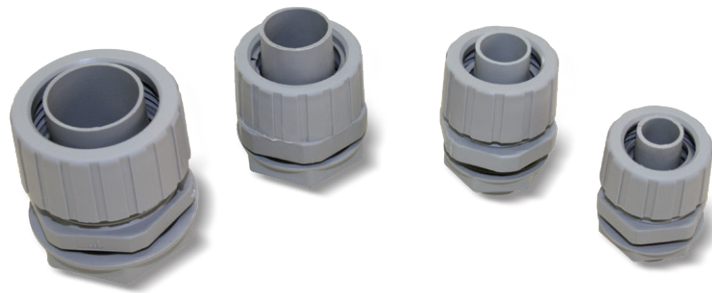

### RACCORDI RTPR

Art.	d Ø	A	B	C	D Ø	E	G	H	L	Materiale	Colore	Peso g
<b>RTPR 3/8"</b>	G3/8"	14.5	8.5	26	12.0	23.5	6	28	46.5	pvc	grigio	12
<b>RTPR 1/2"</b>	G1/2"	14.5	9.0	28	15.5	26.5	7	33	50.0	pvc	grigio	18
<b>RTPR 3/4"</b>	G3/4"	14.0	10.5	35	20.8	26.5	9	38	51.0	pvc	grigio	26
<b>RTPR 1"</b>	G1"	16.0	9.0	41	26.5	32.5	10	44	57.5	pvc	grigio	36

Temperatura di esercizio: -10° / +60 °C

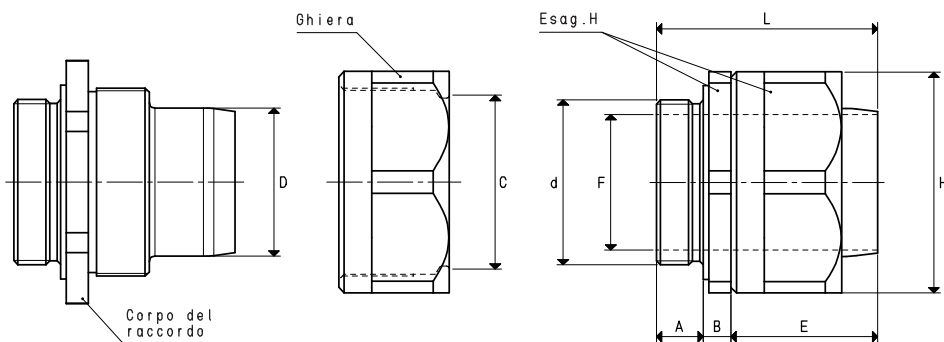

### RACCORDI RMTPR

Art.	d Ø	A	B	C Ø	D Ø	E	F Ø	H	L	Materiale	Per tubo TPR	Peso g
<b>RMTPR 1" 1/4</b>	G1" 1/4	13	8	42.7	36.5	33	33	54	54	alluminio anodizzato	TPR 1" 1/4	360
<b>RMTPR 1" 1/2</b>	G1" 1/2	15	9	48.7	41.8	40	38	62	64	alluminio anodizzato	TPR 1" 1/2	390
<b>RMTPR 2"</b>	G2"	17	10	60.8	53.5	48	49	80	75	alluminio anodizzato	TPR 2"	440

Temperatura di esercizio: -20° / +60 °C

Rapporti di trasformazione: N (newton) = Kg x 9.81 (forza di gravità); inch =  $\frac{\text{mm}}{25.4}$ ; pounds =  $\frac{\text{g}}{453.6} = \frac{\text{Kg}}{0.4536}$

Adattatori per filettature GAS - NPT disponibili a pag. 1.130